

SECTION A
SCALE 1:90

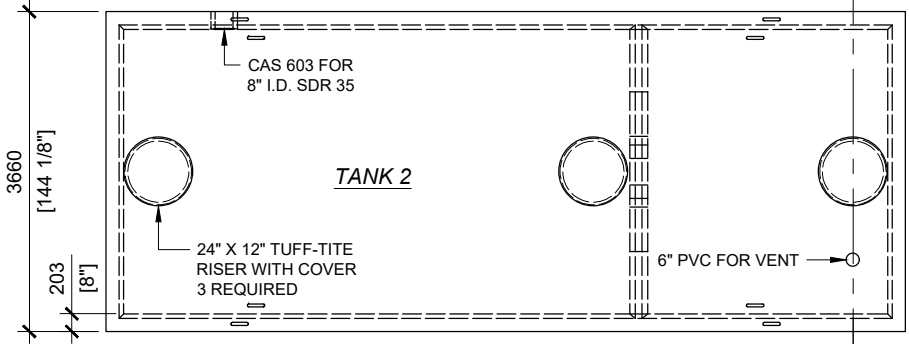

TOP VIEW
SCALE 1:90

GENERAL NOTES:

1. ALL DIMENSIONS ARE IN MILLIMETRES UNLESS NOTED OTHERWISE.
2. PRECAST CONCRETE TANK DESIGNED TO CSA B66 DESIGN, MATERIAL AND MANUFACTURING REQUIREMENTS FOR PREFABRICATED SEPTIC TANKS AND SEWAGE HOLDING TANKS.
3. TANK DESIGNED FOR A MAXIMUM FILL COVER DEPTH OF 1000 mm, NO MINIMUM FILL COVER DEPTH, AND 12 kPa VEHICLE LOADING.
4. GROUT TO BE NON-SHRINK CEMENTITIOUS GROUT WITH MINIMUM COMPRESSIVE STRENGTH OF 45 MPa.
5. JOINT SEAL TO BE CONSEAL CS-102 BUTYL RUBBER SEALANT (CONFORMS TO AASHTO M198B AND ASTM C99091). STORE, HANDLE AND APPLY JOINT SEALS IN STRICT ACCORDANCE WITH MANUFACTURER PRODUCT DATA SHEETS.
6. IT IS STRUCTURALLY IMPORTANT THAT THE SEALS IN THE HORIZONTAL JOINTS BE INSTALLED CORRECTLY. TOP UNIT MUST BE INSTALLED WITHOUT SLIDING THE UNIT ON THE SEALS.
7. DESIGN BASED ON GRANULAR BEDDING AND BACKFILL COMPACTED TO 95% SPDD.
8. LIFTING INSERTS TO BE GROUTED ON SITE BY OTHERS.
9. DELIVERY IS MADE BY CRANE-EQUIPPED TRUCKS.
10. EXCAVATION MUST BE READY, SAFE AND ACCESSIBLE FOR UNLOADING FROM THE REAR OF THE TRUCK.

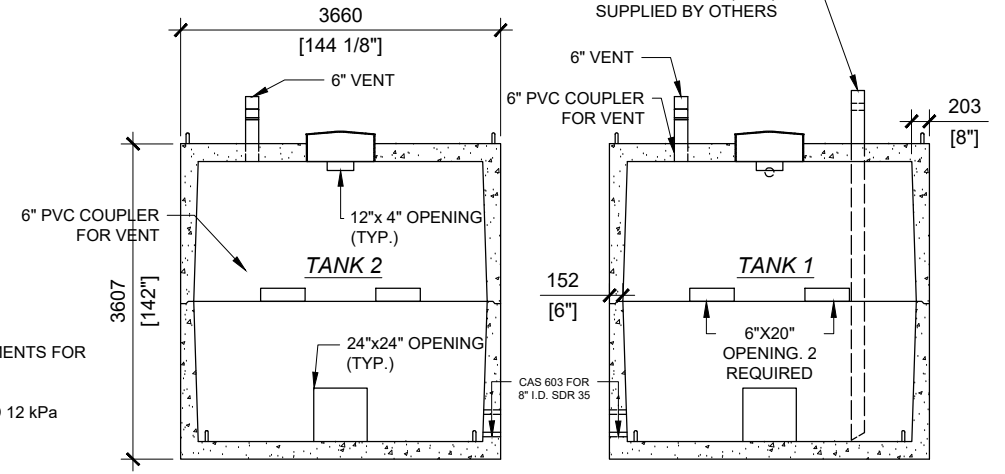

SECTION B
SCALE 1:90

11. MINIMUM OVERHEAD CLEARANCE OF 18 FT. IS REQUIRED.
12. ALL UNITS MUST BE HANDLED WITH PROPER LIFTING EQUIPMENT (i.e. SPREADER BARS).
13. BEDDING, BACKFILL AND ALL OTHER SITE WORK BY OTHERS.



MANUFACTURED:
OTTAWA, ON
613-822-1488
www.powerprecast.com

CONCRETE TYPE: SCC
CONCRETE: 45MPa
AIR CONTENT: 6.5% ± 1.5%
REINFORCEMENT : STEEL TO CSA CAN A23.4-05 / A23.3. G30.18 Fy=400MPa

WEIGHT:
Bottom - 78,034lbs / 35,470kg
Top - 77,761lbs / 35,346kg
CSA APPROVED

SHEET:
1/1
DWG NO.
T - 3.25
DRAWN BY:
E.ZHOU
DATE:
MAY/2020

86000L(18900 Gal.) Linked Fire Water Tank
2-LINKED FIRE WATER TANKS