

TOP VIEW
SCALE 1:50

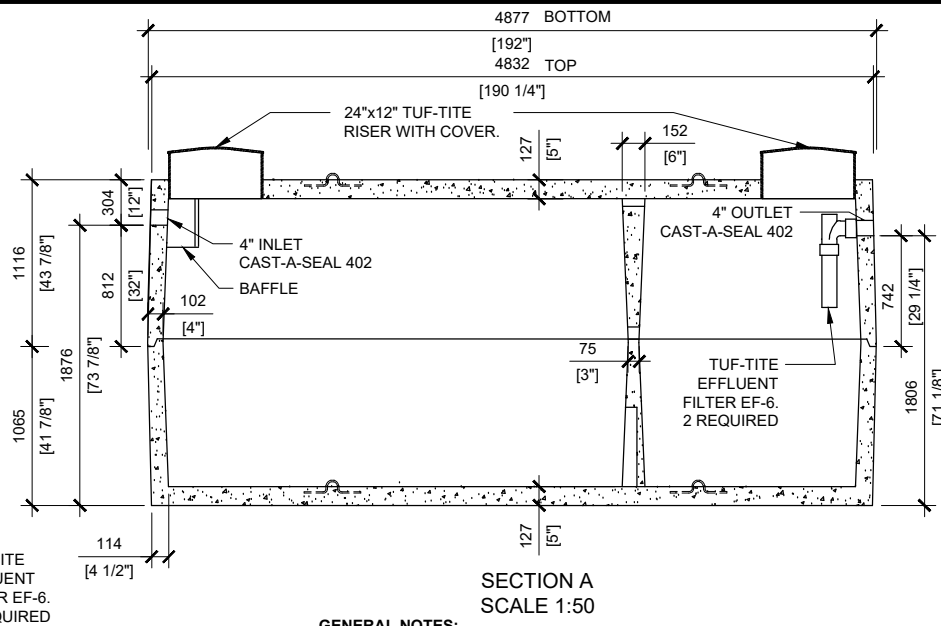

SECTION A
SCALE 1:50

GENERAL NOTES:

1. ALL DIMENSIONS ARE IN MILLIMETRES UNLESS NOTED OTHERWISE.
2. PRECAST CONCRETE TANK DESIGNED TO CSA B66 DESIGN, MATERIAL AND MANUFACTURING REQUIREMENTS FOR PREFABRICATED SEPTIC TANKS AND SEWAGE HOLDING TANKS.
3. TANK DESIGNED FOR A MAXIMUM FILL COVER DEPTH OF 1000 mm, WITH 4.8 kPa LIVE LOAD, AND NO VEHICLE LOADING.
4. GROUT TO BE NON-SHRINK CEMENTITIOUS GROUT WITH MINIMUM COMPRESSIVE STRENGTH OF 45 MPa.
5. JOINT SEAL TO BE CONSEAL CS-102 BUTYL RUBBER SEALANT (CONFORMS TO AASHTO M198B AND ASTM C99091). STORE, HANDLE AND APPLY JOINT SEALS IN STRICT ACCORDANCE WITH MANUFACTURER PRODUCT DATA SHEETS.
6. IT IS STRUCTURALLY IMPORTANT THAT THE SEALS IN THE HORIZONTAL JOINTS BE INSTALLED CORRECTLY. TOP UNIT MUST BE INSTALLED WITHOUT SLIDING THE UNIT ON THE SEALS.
7. DESIGN BASED ON GRANULAR BEDDING AND BACKFILL COMPACTED TO 95% SPDD.
8. LIFTING INSERTS TO BE GROUTED ON SITE BY OTHERS.
9. DELIVERY IS MADE BY CRANE-EQUIPPED TRUCKS.
10. EXCAVATION MUST BE READY, SAFE AND ACCESSIBLE FOR UNLOADING FROM THE REAR OF THE TRUCK.
11. MINIMUM OVERHEAD CLEARANCE OF 18 FT. IS REQUIRED.
12. ALL UNITS MUST BE HANDLED WITH PROPER LIFTING EQUIPMENT (i.e. SPREADER BARS).
13. BEDDING, BACKFILL AND ALL OTHER SITE WORK BY OTHERS.

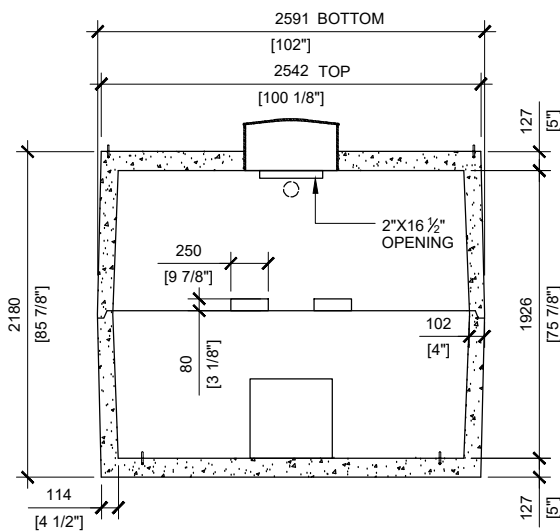

SECTION B
SCALE 1:50

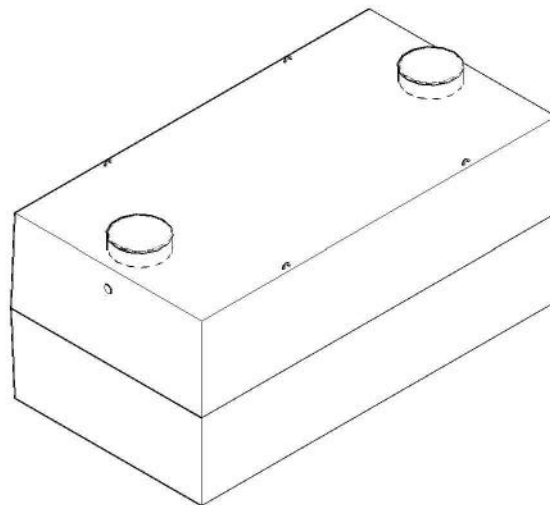

* AVAILABLE FOR TRAFFIC LOADING



MANUFACTURED:
OTTAWA, ON
613-822-1488

www.powerprecast.com

CONCRETE TYPE: SCC
CONCRETE: 45MPa
AIR CONTENT: 6.5% ± 1.5%
REINFORCEMENT : STEEL TO CSA CAN
A23.4-05 / A23.3. G30.18 Fy=400MPa

WEIGHT:
Bottom - 17,712lbs / 8,050kg
Top - 17,571lbs / 7,989kg
CSA APPROVED

SHEET:
1/1

DWG NO.
T - 3.02

DRAWN BY:
E.ZHOU

DATE:
FEB/2020

18200L (4000 Gal.) Septic Tank

PPS REFERENCE: 409261 - TOP 409260 - BOTTOM