

FEMALE END VIEW
SCALE: 1:25

SIDE VIEW
SCALE: 1:25

MALE END VIEW
SCALE: 1:25

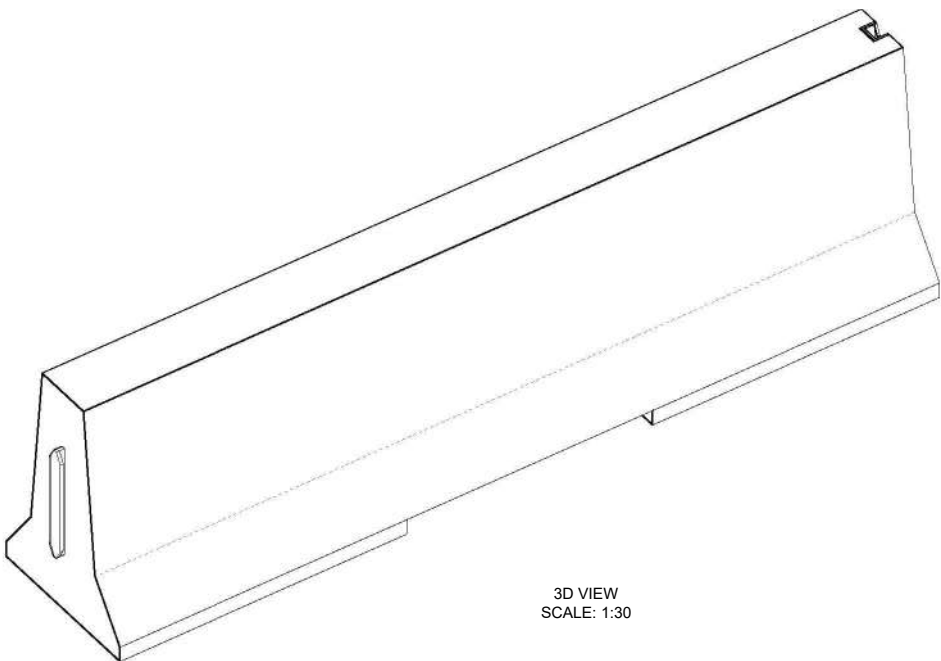

3D VIEW
SCALE: 1:30

GENERAL NOTES:

1. ALL UNITS MUST BE HANDLE WITH PROPER LIFTING EQUIPMENT.
2. REINFORCING AND STIRRUPS SHALL BE SIZE 15M, GRADE 400W, DEFORMED STEEL BARS. CONCRETE COVER SHALL BE 50MM MINIMUM.
3. ALL CONCRETE EDGES SHALL HAVE 15X45° CHAMFER
4. WELDS SHALL BE ACCORDING TO CSA W59 AND CSA W186.
5. ALL DIMENSIONS ARE IN MILLIMETRES UNLESS OTHERWISE SHOWN.
6. AS PER OPSD 911.143



MANUFACTURED:
OTTAWA, ON
613-822-1488

www.powerprecast.com

CONCRETE TYPE: SCC
CONCRETE: 45MPa / 6,526PSI
AIR CONTENT: 6.5% ± 1.5%
REINFORCEMENT : STEEL TO CSA CAN
A23.4-05 / A23.3. G30.18 Fy=400MPa

AS PER O.P.S.D. 911.143
YEAR: NOV. 2013
WEIGHT: 10,606lbs / 4,821kg

SHEET:
1/1

DWG NO.
B - 1.09

DRAWN BY:
A.A-Hamid

DATE:
DEC/2019

4M I-LOCK TALL WALL BARRIER

PPS REFERENCE: 410096